

# **SME**

**SOCIETY FOR MINING, METALLURGY,  
AND EXPLORATION, INC.**

**PO BOX:625002●LITTLETON COLORADO●801162-5002**

**PREPRINT  
NUMBER**

**98-172**

## **DEVELOPMENT OF THE FALCON CONCENTRATOR**

S.A. McAlister and K.C. Armstrong

Falcon Concentrators Inc.  
9663-199A Street  
Langley, British Columbia  
V1M 2X7, Canada

For presentation at the SME Annual Meeting  
Orlando, Florida --- March 9-11, 1998

## ABSTRACT

This paper outlines the development of the Falcon enhanced gravity separator. Design objectives included continuous operation with sharp separations, mechanical simplicity, minimization of process water demand, the ability to apply a centrifugal field up to 300G's, unit capacity in excess of 100 t/h within a footprint of 10 square meters, a capital cost below \$US 4,000 per t/h capacity, and total operating costs of less than \$US 0.40 per tonne. A parallel development has been inexpensive, effective, semi-continuous equipment for recovery of precious metals in the free metallic state. These objectives have been largely met. There are significant opportunities for the technology in many mineral processing applications.

## INTRODUCTION

**History:** Enhanced gravity separation devices (centrifuges) have been patented for over a century but were impractical until recently. The physical laws behind the concept were well understood but engineering had to catch up with the science. This included the development of abrasion resistant materials, the improved design of rotating equipment that allowed higher RPM, and a good understanding of slurry flow, rheology, and the effects of particle shape. Only in the last decade has engineering entered the dawn of enhanced gravity separation. The more we learn, the more we realize how little we know. A parallel can be found in the history of the hydrocyclone which, although in widespread use for decades, experienced an upsurge of study and improvement after 1960 and which continues to receive attention in the literature. Mineral processing technology has advanced across the boards recently and enhanced gravity separation has been part of this evolution. A few things are now known with some certainty.

**Capacity:** While units have previously been defined by diameter, capacity is more a function of surface area. Two units of close diameter must be assessed by rotor surface for comparison. Within the Falcon SB product line from 104 to 965 mm (4" to 38") diameter, the surface area increases by  $D^2$  and rated t/h capacity increases by  $D^{2.4}$ .

**Efficiency:** A constant separation efficiency can be maintained in the same machine at higher throughput by increasing the G's. With a constant throughput, a lower  $D_{50}$  will be achieved by increasing the G's, where  $D_{50}$  is the particle density at which 50% of those particles are recovered.

**Pulp Acceleration:** Pulp must be accelerated to the rotor RPM when fed into an enhanced gravity separator, and acceleration is most practically done by a coaxial impeller. Tests without the impeller have shown a thicker flow up the bowl wall which can only be due to slurry spiraling up at less than full RPM and the available G's. Only a Falcon machine has an impeller.

**Particle Shape vs enhanced Gravity:** An observation with early enhanced gravity separators was that flake gold was readily recovered when it was not at 1G although the actual mechanism(s) is unknown. Particle shape effects as observed empirically at 1G appear to differ with these separators.

**Background theory:** The statements above are based on observations. Gravity theory is complex but a short comment is

in order. (5) In all types of enhanced gravity separators the influence on a particle and hence the velocity is proportional to the G force. Stokes law for the terminal velocity of spheres falling in a liquid can be generalized as:

$$V = K \times D^2 \times G \times (SG_{\text{particle}} - SG_{\text{medium}})$$

where K is a constant related to viscosity and the units used, D is particle diameter, and G is multiple of the earth's gravitational pull of 9.8m/s. Figure 1 shows the settling velocities for two sets of spherical particles at 1 and 200G derived from this law. Smaller particles at higher gravities develop enough velocity to reach the concentrate during the short retention time.

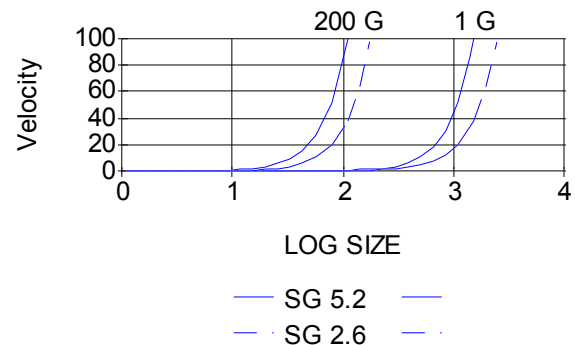

Figure 1. Change in relative terminal velocity with enhanced gravity for two minerals of 5.2 and 2.6 SGU at one and 200 G.

## MODEL B ENHANCED GRAVITY SEPARATOR

**Prototype development:** One of the authors (McAlister) was aware of fine gold in the sand/slime streams of commercial gravel operations in the lower Fraser Valley (BC) that drew their feed from old river gravel deposits. Mercury was not an option and modern sluices did not work. The idea was to wrap a sluice around a vertical axis and use enhanced gravity to sharpen the separation, giving an inverted cone. The horizontal component of the centrifugal force would be used for separation while the vertical component became the hydraulically downhill force. A short cylindrical section and a small lip formed a single riffle to trap the gold flakes. Inserting the separator in the circuit would not alter the water balance. First tested in 1981, the design through trial and error over several years produced most of the present details like an impeller to fling the feed to the walls, a cone angle around 14 degrees, and rubber surfaces. A hollow drive allows concentrate to exit.

**Separation Mechanism:** The Falcon's cone, which is called the migration zone, contains a flowing bed with a large amount of interlayer shear. Particle settling velocity is enhanced by the excess gravity, so fine heavy ones arrive at the wall before coarse light ones. Further up where particles begin to compact they are still moving in layers and spaces open between them into which small denser minerals can move. These particles can work their way into the wall layer and may push coarser light ones out of it. The Falcon mechanism is called flowing film separation. Segregation should be complete when the stream arrives at the retention zone. RPM can be adjusted to change the

settling rates and compensate for feed changes.

**Installations:** Blackdome Mines in 1986 became the first commercial application when a B10 254mm (10") recovered significant gold from shaking table tails in a ball mill/jig/table circuit and produced smelting grade concentrates of up to 30% gold metal in one pass. Overall recovery of gold improved by 6% in this gravity/float mill. This recovery from table tails highlighted the superiority of enhanced gravity. (16) In 1989 the first B20 (0.5M) became the first Falcon enhanced gravity separator to handle the entire throughput of a mill plus recycled float cleaner tails when used to treat the cyclone overflow at the 400 TPD Johnny Mountain Mine. A conventional jig/table circuit in grinding had been followed by spirals on the cyclone overflow before copper/gold flotation. The spirals recovered one kg for every 4-5 kg of jig gold for a total up to 40%. Spirals increased net recovery by 4-6% but the need for much operator attention was a problem. When they were replaced by a B20, recovered metal rose to one kg of gold per three kg of jig recovery. A changing feed type with lower gravity gold and new flotation strategies prevented quantifying the net effect on recovery. B20 concentrate was cleaned on a B6, tails went to the 150-500 g/t copper concentrate. Other applications followed with B12 and B20 production units. Lab sized B6's went to producing mines and to corporate, consultant, and university labs. Tests on different materials and for other applications expanded the knowledge base. (15)

Fig. 2. Falcon B showing cone and cylindrical retention zone.

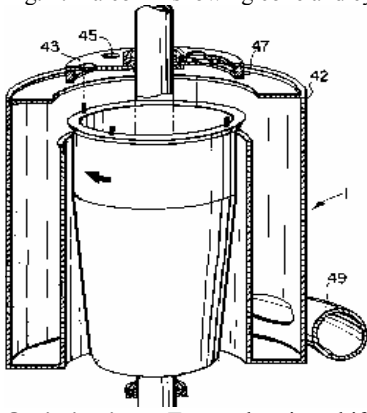

**Optimization:** Testwork using shift data at Johnny Mountain showed constant rate recoveries from 8-24 hours suggesting that the concentrate bed was recovering gold without indications of saturation. This manual machine was tedious to unload so dayshift cleanups were used to reduce labour and to increase security. Cleanup time from the same stream dropped from 2+ hours for the spirals to 15 minutes per day. Gold recovered was 80% minus 50µ. This machine worked with up to 20% sulphides in the feed without adverse effect. A second ball mill was added to the mill and while the B20 worked well on primary cyclone overflow, it was poorer with the secondary cyclone overflow. This led to a further understanding of the cone angle, finer feeds need higher angles, fixed in later units at 14 degrees. At Campbell Red Lake Gold Mines a calcine stream was scavenged to make furnace feed at up to 60% gold before cyanidation. This gold was all finer than 25µ. Studies showed an initially high metal mass recovery then a long term slower gain (Fig. 3). In the retention zone the concentrate bed is packed but the fine dense mineral can work its way between the coarser particles and stay. The top of this bed is in dynamic balance with scouring by the tails flow but eventually is either covered with oversize tramp or the openings between larger particles become plugged with fines. This initial growth of the bed

followed by the slower accumulation is consistent with the pattern in Figure 3. (staff, personal communication)

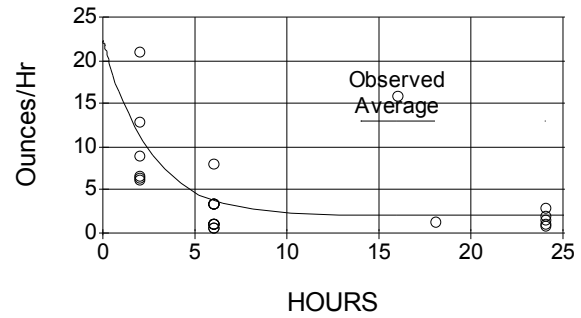

Figure 3. Recovery rate at Campbell Red Lake. A dropoff in recovery with time suggested shorter collection cycles.

**Automation:** Variable frequency motor drives and good programmable controllers were becoming cheaper so Falcon designed the AutoPAC in 1990. It controls the rotor RPM and the feed valve, plus it could interlink with other devices. This greatly lowers the startup stress on the drive train, gives the operator control of which bowl speed to use after testing the ore, and allows the bowl to reduce speed quickly then turn slowly while being cleaned. Washing can be done using a few small sprays to fluidize the concentrate in two or three turns, keeping the concentrate to >30% solids. Total off time is 30-40 seconds. By contrast, a competing enhanced gravity separator uses an automation package that requires much more wash water, takes over four minutes per cycle, employs a fixed speed drive, and costs 50% more. Automation also reduces labour and increases security. Cycle times are typically 90 minutes but are ore specific. This drops the concentration ratio to around 1000 but the increased product mass can be reduced by feeding it automatically to a smaller unit under control of the AutoPAC.

### SB "SUPER B" MACHINE

**Elutriation:** Another enhanced gravity device was patented in 1935 by A. N. MacNicol (Figure 4). It is also a truncated cone but ribs divide the length into a series of slots. A water jacket and connecting holes are used to inject water and elutriate a bed of material in each. Some companies have produced this type of enhanced gravity separator, the Knelson being the best known. Concentration by a MacNicol is different because it uses a fluidized bed (elution) into which heavier minerals sink. Coarse heavy minerals readily penetrate the bed and displace lighter ones. By adjusting the pressure the operator changes the flow to suit the conditions. With large size differences between the top size of gangue and the targeted mineral, the water flow can prevent fines entry. Parallel tests on the same material showed the Falcon B to be generally poorer on coarser feed and superior on finer feeds. At the same size of feed the Falcon showed better recovery of fine particles. Elutriated bowls could be used in grinding circuits but water consumption per tonne was high and only a portion of the ball mill discharge could be treated. In spite of this their superior recoveries over jigs and the inherently high recirculating load of gold particles due to selective recovery in the hydrocyclones resulted in their replacing jigs in grinding circuits. The Falcon's non use of water made it practical for insertion in any circuit where water was critical.

Figure 4. Drawing for an elutriated bowl enhanced gravity separator from patent 22,055/35 (Australia).

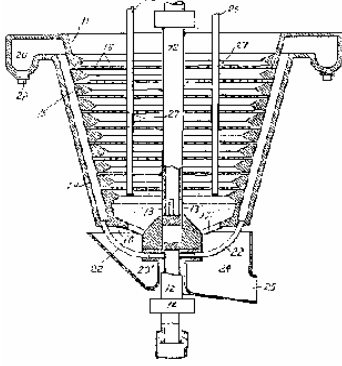

**Two Stage Concentration:** The “Super B” enhanced gravity separator is the first significant improvement to the MacNicol design in 60 years. It was conceived in 1994 as the combination of the best of both technologies. The Falcon migration zone was kept but the retention zone was to be elutriated to see if it would improve coarser gold recovery and handle coarser feed. Two concentric cylinders with end caps formed a water jacket with short holes through the inner wall. The retention zone was subdivided into a few slots for several reasons. With only 1/3 of the length having water injection, the total water consumption was kept low. All holes were at the same radius, so distribution of bed water was guaranteed. (Fig. 5)

**Installations:** The first SB machine, an SB21, was field tested on an alluvial deposit in central British Columbia in 1995. It performed with excellent recovery and without mechanical incidents or plugged holes. The same unit was then used at the QR mine without modification. In the first 24 hours production was in the kilograms of metal range and 25-40% recoveries were achieved after that. A scaling problem with the water inlets was solved later through the use of chemical inhibitors. The Mazowe plant in Africa found that gravity recovery went from 57 to 77%, cyanidation capacity downstream was liberated, and overall recovery rose 4%. Savings in labour, power, and maintenance alone gave a two year payback. Installation of an enhanced gravity separator in a gold plant does not always increase recovery measurably but will usually reduce costs. If it is followed by a cyanidation circuit there are significant savings in reagents, and if followed by flotation the revenue in bullion form usually surpasses that from metal in a flotation contract. Although each plant is different and companies understandably cannot disclose detailed economics, Falcon believes that all downstream savings should be considered when evaluating a purchase. (1,2,3,4,6,14,18)

Since then SB machines have been replacing other devices around the world. Production units are made in 305, 530, and 965 mm (12, 21, and 38”) diameters. Wear parts costs are typically less than \$US 0.01/MT with a maximum \$0.03/MT in a severe application. Rated at 60 t/h, the workhorse SB38’s have a power consumption of 0.5 KWH/MT. Throughput at some plants has exceeded 90 t/h of -6mm material. FOB Langley, BC costs with the AutoPAC are under \$US100,000. A 1.47M SB58 version rated to 200 t/h has been designed.

**Lab work:** A 100 mm (4”) lab unit collects about 100 grams of concentrate, enough for screen and assay. The recommended 5 kg. batch of feed gives a 50:1 mass concentration, high enough to define gravity recoverable gold in low grade samples. This

large original sample became a useful tool for geologic assessment and testwork. Tests at independent labs using the same feeds have shown the SB4 to recover more mineral at higher grade than in lab devices using the MacNicol design. A study was done by Anicia, et al. using synthetic quartz ores with ilmenite as a heavy mineral gangue and tungsten metal to imitate gold. All showed 90 to 100 percent recovery by the SB4 in this exceptional case (there were no middlings). Galena from quartz separations were also demonstrated. (2)

**Selectivity:** Galena with a high SGU and a cubic form should be a serious interference to gold recovery. At the Lepanto gravity/CIP mill, however, an SB38 achieved 30-35% recovery when the previous enhanced gravity separator at lower G’s averaged 4.5%, both in the presence of galena. (19)

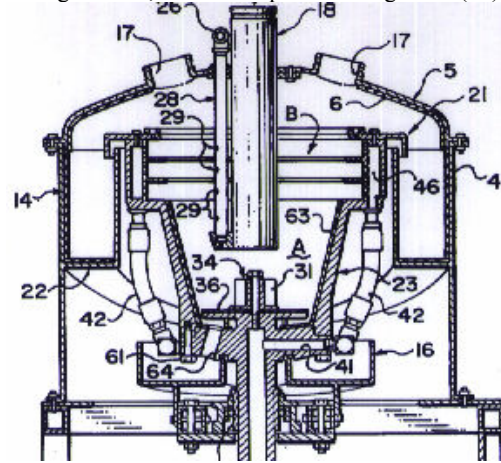

Figure 5. Falcon SB series concentrator showing the elutriated retention slots (B), feed pipe (18) wash sprays (29) feed impeller (31) water jacket (46) and concentrate outlet (64).

## CONTINUOUS “C” MACHINES

**The Need:** Ongoing trends in the mineral industry have been toward large tonnage operations with economies of scale using high capacity devices. (17) A gravity separator for <1mm with continuous output, high capacity, no water addition and easy operation did not exist. While spirals are usually good separators (albeit with some water) it was thought that a continuous or “C” Falcon could fill a major need. The retention zone was subdivided into hoppers with air operated valves to control the flow. First tested in 1987 at the Blackdome mine, the design faced major hurdles. C20 (510mm) units were developed followed by a C10 lab model to allow a realistic scaleup procedure. (17)

**C20 Applications:** The first use was in the Lupin gold mine where the objective was the collection of auriferous arsenopyrite from cyanide tailings for regrinding and return to the cyanide circuit. While the C20 was technically successful, the cost of flown in fuel for regrind mill energy and the gold price did not allow enough margin for permanent installation. Tantalum Mining Corporation of Canada Limited permanently installed a C20 as a scavenger on final tails after an extensive evaluation period. Typical performance was 70% metal in 30% mass. Key observations were that maximum RPM was superior and that higher feed densities gave better recovery in lower mass. Recoveries of 70% of the -20µ tantalum were superior to that of spirals. (7) C units have been used for iron, titanium, tin, pyrite, zircon etc. in tailings or float concentrates.

Table 1. Operating costs for a C20 at 12 t/h.

ITEM	UNIT	UNIT/t	\$US/tonne
Parts	\$US	\$0.084	\$0.084
Labour	HR	0.0008	\$0.023
Power	KwH	0.83	\$0.042
TOTAL	n/a	n/a	\$0.149

**Low SG Applications:** In the coal industry the valuable material is typically SG 1.3-1.6 and rejection is desired for the ash at 2.6 SGU to raise the product value. Pyrite if present carries sulphur. SO<sub>2</sub> is currently a penalty above 2.5 lb/MBTU in the US. Flotation of coal away from the gangue is the only technology to handle the fine material but in many mines the pyrite will float while in others the coal is oxidized and will not float. Flotation costs often exceed the value of the product but overall economics of cleaning coal are too complex to elaborate on here. (8) A 10% coal middling particle will probably float but will have a density close to that of ash or pyrite and report as gangue when using gravity methods. One G devices have been used but with fines below 100 mesh (149µ) they were inefficient. Good ores are mined first and an increasing proportion of the remaining US coal reserves will produce fines. The potential for enhanced gravity to clean fine coal was seen by Dr. R. Honaker of Southern Illinois University in 1992. Tests with Illinois #5 coal using a B6 showed a release curve better than that for flotation for the same seam. (10)

Table 2. Analysis of a coal used for enhanced gravity separator parameter testing at Southern Illinois University.

Illinois No. 5 Coal					
Size microns	weight %	Ash %	T sulphur %	Py S %	BTU/lb
>210	33.1	23.83	3.75	2.51	10,847
210 x 37	32.4	21.68	4.05	3.04	11,079
<37	34.5	64.75	1.64	1.26	4,600
Totals	100.0	37.25	3.12	2.25	8,767
DISTRIBUTIONS					
Size microns	Ash %	T sulfur %	Py S %	BTU %	
>210	21.2	39.8	36.9	41.0	
210 x 37	18.9	42.1	43.8	40.9	
<37	60.0	18.1	19.3	18.1	

**C10 Testing:** When tests of other seams also showed encouraging results, the first C10 was installed in a closed loop reservoir/pump system and optimized. A competitor's prototype 300 mm (12") continuous Elutriated Bowl (EB12) machine was also tested. Comparisons of Economic Efficiency (EE) defined as % coal recovery minus % ash content were used to normalize comparisons. The results on -595µ coal showed that the optimum economic efficiency for 595 x 149µ was at 72 G's while the 149 x 37µ size was best at 125 G's. Neither unit showed upgrading in the -37µ range. Further work showed that Falcon efficiency extended to 10µ then dropped off. (10) Colloidal (<10µ) sized particles have near-zero settling velocities and would be expected to follow the water. With <20% fuel value in the -37µ feed, desliming either feed or cleaned coal by cycloning was noted as a cheap additional step. While the EB12 had a limit of 0.3 t/h then fell off sharply, the C10 efficiency

dropped slowly from 0.8 t/h and no overload rate was found to 1.6 t/h, see figure 6. (12) The EB12 did not significantly reject sulphur below 200µ and was dropped from further testing. Flotation has shown ability to clean ash from fine coal but has not been as successful with the rejection of pyritic sulphur. Spirals have superior rejection vs. flotation above 100µ. The C10 was compared to both by using the same feedstock. Figure 7 shows the sulphur content of the three products and the feed. A separation density of 1.6 SGU was observed for the C10, lower than that of any previous device using a water medium. (9,10)

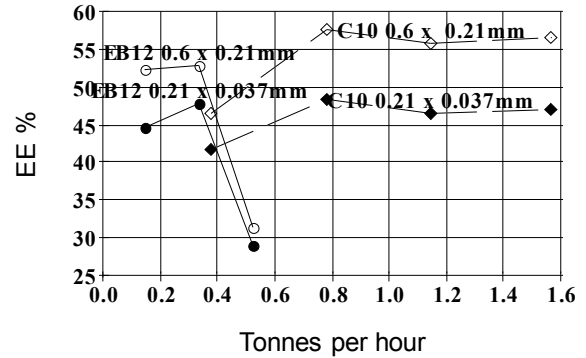

Figure 6. Comparison of competitor's prototype elutriated bowl and Falcon C10 separators. Adapted from Fig. 4 ref. 12.

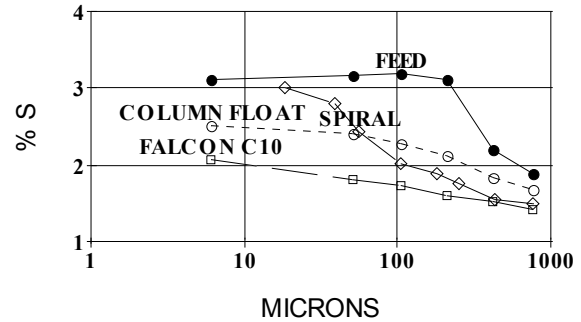

Figure 7. Comparison of sulphur levels in concentrates by size when cleaning coal using a Falcon C10, an MDL LD-9 spiral and a Packed Column (flotation). Adapted from Fig. 7 ref. 12.

**C40 Testing:** C10 results suggested a cost effective method to produce compliance coal. Faced with C20 capacities of only 15-20 t/h, Falcon designed and built the first C40 (1 meter) unit for high throughput testing. Extensive testwork at SIU demonstrated a capacity of 94 t/h with throughput. A second aspect of scaleup is metallurgical performance. C40 release curves had slightly better +149µ and slightly lower -149µ performance than the C10 (Figure 8). SIU ran this unit for 170 hours without a hint of maintenance trouble. Costs (Illinois) were <\$0.10/t for power at 50 t/h. (13) This and a second C40 have since been used on other ores. Although no results are available for reco/h without finding an upper limit. Efficiency increased slightly varies, rates of 100 t/h have been reported. Scaleup of the C40 from the C10 was 20 times by separation area but since neither machine was tested to overload the T/H ratio was not found. Until more ores can be tested to the maximum on both units a 28:1 scaleup from C10 data to a C40 planned installation is recommended.

## FUTURE TRENDS

**Falcon B:** Gold cleanup to furnace feed is best done using a Falcon B without consideration of the water balance and multiple passes increase recovery. Falcon is adapting the B technology to materials that have fewer fines and a higher percentage of heavy minerals. A common problem with gravity circuits can be the production of smelting grade concentrate with >50% gold or valuable mineral. One simple method has been proposed by Prof. A.R. Laplante. The enhanced gravity separator is first fed with coarse magnetite then with material to be cleaned. Concentrate is cleaned with a magnet to yield recyclable magnetite and furnace feed. The tails can be rerun to scavenge until no more gold is collected.

**Falcon SB:** Over 100 applications of this type have been made in the last 24 months. Feedback indicates that there is little to improve on except in the areas of water consumption and concentrate grade. Development in these areas is proceeding in a way which is compatible with existing operating machines.

**Falcon C:** The sharpness of separation is being worked on. Falcon one meter C40 enhanced gravity separators have demonstrated the ability to make compliance coal at low cost. They would be used either alone or in series with a desliming cyclone. Continuous units have a potential in base and ferrous metals and in cleanup of industrial and waste dump sites. Their characteristics suit them more as roughers or scavengers followed by other devices. A possible application is in the removal of sulfides or heavy mineral from tailings, either for the recovery of associated values as at Lupin or to create a bulk low sulphur tailings and a smaller high sulphur tailings for separate disposal. Mass of the concentrate with the C series enhanced gravity separator was found to be 5-70% of the feed. Used in rougher/scavenger/cleaner configurations like flotation cells but without the added water or reagents, C units should give a better recovery and could produce concentrates of higher grade than they do at present. There is no other continuous gravity separator on the market that has either the capacity, the metallurgical performance, or uses no water. Capacities range to 2,000 MTPD in a 3 x 3 meter footprint at an FOB cost of <\$US350,000 with an AutoPAC. Two related characteristics of C machines deserve mention. First, concentrates are highly deslimed (10 microns and less) and second they are dewatered to 70% solids or more. This has been investigated for the production of backfill. Other applications are direct feed to a grinding, leaching, or other circuit that needs a high percent solids or low slimes level.

**Other:** In the future automation will allow an on stream analyser to monitor a stream and feedback control of the mass split as is now done with flotation control. Particle size analysers can be used to optimize the RPM to match feed size. Development continues on the Falcon D.

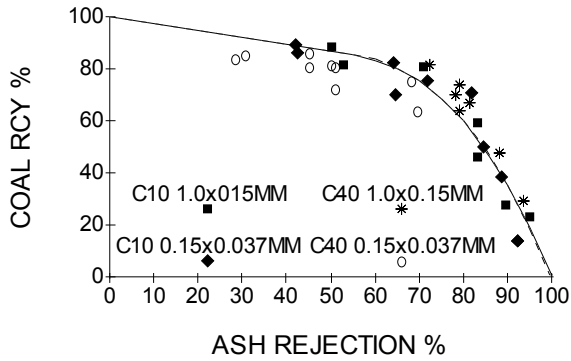

Figure 8. C40 results vs C10. Performance curves of the C10 for the two size ranges (both shown) were almost identical. Adapted from Figure 3 ref. 13.

**Mineral Sands:** One world scale mineral sand deposit has not been developed because the contained titania mineral grains are predominantly 30-50 $\mu$  making them difficult or impossible to recover economically with previous gravity technology. Recent testing with a C10 concentrator indicated that the heavy minerals can be economically concentrated. Of particular interest in this work was the fact that the ROM feed did not have to be deslimed. The concentrate was sufficiently dewatered to allow direct attrition scrubbing and it was deslimed, both steps were necessary for the intended following process.

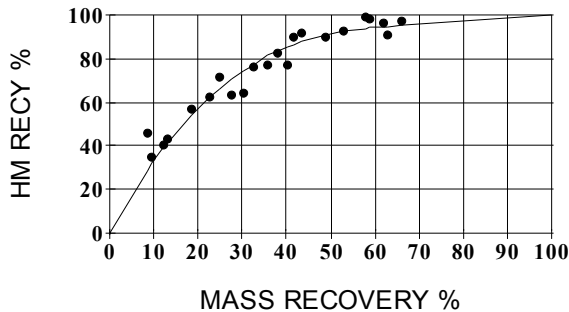

Figure 9. Metal vs mass recoveries for a titanium ore.

**Ferrous metal:** An iron mine using flotation to separate gangue evaluated enhanced gravity for the reject. The first 60% recovery carried little gangue. (Figure 10.) Recycle of Falcon concentrate to flotation feed, possibly after regrinding, is being investigated.

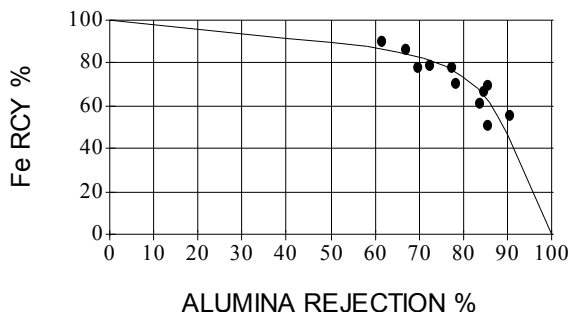

Figure 10. Fe/alumina release curve for iron tailings.